

Trade Data



NV_x

Gas Fired Unit Heaters

NVF Axial Fan - Crossflow and Downflow

NVC Centrifugal Fan

NVD Duct Heater

Heat Outputs from 10kW - 140kW

Issue 1.2 - May 2011



Authorised User No. 00175

Product Overview

Benefits

Installer Friendly

- New compact model
- Horizontal wall exit flue discharge option (no roof work)
- Room sealed or fan assisted flue
- Interchangeable top or rear flue/combustion air spigot positions
- Centrifugal fan option

Caring For The Environment

- High Efficiency
- ECA Approved Models

Peace Of Mind

- More Than Sixty Years Experience in Warm Air
- Two Year Parts And One Year Labour Guarantee
- Ten Year Heat Exchanger Warranty

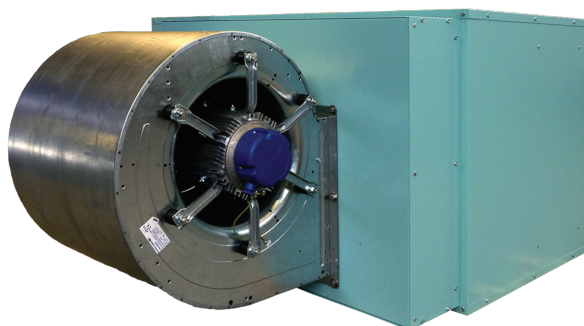

NVx Centrifugal heater front and rear view

Application and Configuration The nvx range of gas fired unit heaters comprises twelve models with outputs ranging from 10 kW to 140 kW. The heaters are typically installed directly into the space to be heated with ducted applications satisfied using the centrifugal fan option. Suitable for either natural or lpg gases heaters can be specified arranged for on/off, high/low or modulated heat outputs.

Efficiencies Favourable levels of fuel usage and reduced emissions are a key element of nvx heater design, further enhanced by the deployment of low NOx combustion technology. Additionally, all heaters have efficiencies which meet or exceed the requirements of both current Building Regulations and the United Kingdom Enhanced Capital Allowance scheme. Efficiencies can be further enhanced with the selection of the modulating burner option.

Cabinet The heater unit is of unitary construction and provided with a separate compartment with a full width hinged and lift-off door giving easy access to heater function controls, gas valve and burner. The cabinet is finished with durable epoxy powder coat stove baked paint.

Heat Exchanger Four pass tubular assembly manufactured from aluminised steel formed, swaged and expanded without recourse to stress inducing welding. 409 and 316 grade stainless steel options available.

Burners Multi burner in-shot matched to each tube assembly and manifolded to a common gas valve and ignition system, itself complete with flame monitoring and safety controls and supplied ready for use with natural gas (G20). Alternative lpg propane (G31) firing available to order.

Air Movement Axial fan heaters are, dependent upon model, fitted with either single or multiple fan sets and discharge warmed air directly into the heated space via adjustable louvred horizontal grilles. As an option a punched type grille is also available. Centrifugal fan models are fitted with the centrifugal fan mounted directly to the heater and discharge via a duct outlet spigot mounted to the front of the heater.

Controls Heaters, as standard, are provided with full ignition and flame protection safety controls, high temperature limit protection and connections for both heat and fan only operation. Heaters may be connected to our compatible environmental control stations which are themselves available in two options. The Powtrol control station provides a digital timeswitch with mechanical day and frost protection thermostats and switching options to enable 'fan only' operation for summer air movement. Alternatively heaters may be specified with the MC200 optimised entry code protected control (mandatory for ECA, high/low and modulating applications) which includes a digital time switch, electronic day thermostat and frost protection thermostats. Remote temperature sensor option available. Interconnecting wiring for all controls is the responsibility of the installer.

Approvals All Powmatic heaters are type tested to meet the stringent requirements of both the Gas Directive and CE accreditation.

NVx

| Model | | | 10 | 15 | 20 | 25 | 30 | 40 | 50 | 60 | 75 | 90 | 120 | 140 | | |
|--------------------------------|----------------|-------------|---------|----------|------|------|------|-------|-------|-------|-------|-------|----------|----------|----------|------|
| Output | | | kW | 10 | 15 | 20 | 25 | 30 | 40 | 50 | 60 | 75 | 90 | 120 | 140 | |
| Airflow | Volume | NV F/ NV C | m³/s | 0.26 | 0.39 | 0.52 | 0.65 | 0.78 | 1.04 | 1.30 | 1.56 | 1.95 | 2.34 | 3.12 | 3.64 | |
| | | NV D | min | m³/s | 0.21 | 0.31 | 0.42 | 0.52 | 0.63 | 0.83 | 1.04 | 1.25 | 1.56 | 1.88 | 2.50 | 2.92 |
| | | | max | m³/s | 0.28 | 0.42 | 0.56 | 0.69 | 0.83 | 1.11 | 1.39 | 1.67 | 2.08 | 2.50 | 3.33 | 3.89 |
| | Throw | NV F | m | 7.0 | 10.0 | 13.0 | 16.0 | 15.0 | 21.0 | 24.0 | 25.0 | 29.0 | 31.0 | 35.0 | 37.0 | |
| | Fan Static | NV C | Pa | 147 | 145 | 177 | 143 | 250 | 236 | 205 | 250 | 260 | 200 | 284 | 285 | |
| Electrics | Supply | Standard | v/ph/hz | 230/1/50 | | | | | | | | | | | | |
| | | Optional | v/ph/hz | 415/3/50 | | | | | | | | | | | | |
| | NV F | Motor | kW | 0.04 | 0.12 | 0.07 | 0.18 | 0.18 | 0.30 | 0.44 | 0.55 | 0.55 | 2 x 0.44 | 2 x 0.55 | 2 x .055 | |
| | | Start | amp | 0.34 | 1.39 | 0.38 | 1.89 | 1.83 | 2.56 | 4.01 | 4.70 | 4.78 | 7.81 | 9.57 | 9.64 | |
| | | Run | amp | 0.16 | 0.51 | 0.28 | 0.62 | 0.61 | 1.35 | 1.96 | 2.44 | 2.51 | 4.22 | 5.13 | 4.98 | |
| | NV C | Motor | kW | 0.37 | 0.37 | 0.37 | 0.37 | 1.10 | 1.10 | 1.10 | 1.50 | 1.50 | 2 x 1.10 | 2 x 1.50 | 2 x 1.50 | |
| | | Start | amp | 8.30 | 8.10 | 7.80 | 8.20 | 14.70 | 14.00 | 16.00 | 24.50 | 24.50 | 58.40 | 42.50 | 39.80 | |
| | | Run | amp | 2.40 | 2.60 | 3.60 | 2.90 | 4.50 | 5.30 | 6.40 | 10.16 | 12.30 | 11.60 | 21.15 | 25.20 | |
| | Fuel | Connection | | BSP/Rc | ¾" | | | | | | | | | | | |
| Minimum Inlet Pressure | | Nat Gas | mbar | 17.5 | | | | | | | | | | | | |
| | | LPG | mbar | 37.0 | | | | | | | | | | | | |
| Consumption | | Nat Gas | m³/h | 1.14 | 1.69 | 2.31 | 2.89 | 3.45 | 4.60 | 5.74 | 6.90 | 8.60 | 10.08 | 13.37 | 15.76 | |
| | LPG | m³/h | 0.44 | 0.65 | 0.89 | 1.12 | 1.33 | 1.78 | 2.22 | 2.67 | 3.32 | 3.90 | 5.17 | 6.09 | | |
| Mounting Height | NV F Crossflow | Min | m | 2.50 | | | | | 3.00 | | | | | | | |
| | | Max | m | 3.00 | | | | | 5.00 | | | | | | | |
| | NV F Downflow | Max | m | 4.0 | 4.0 | 4.0 | 5.0 | 5.0 | 6.0 | 7.0 | 9.0 | 10.0 | 11.0 | 12.0 | 12.0 | |
| Overall Dimensions | NV F | Height | mm | 540 | 540 | 540 | 540 | 760 | 760 | 912 | 760 | 912 | 700 | 831 | 975 | |
| | | Width | mm | 785 | 785 | 1000 | 1000 | 1000 | 1000 | 1000 | 1325 | 1325 | 2325 | 2325 | 2325 | |
| | | Depth | mm | 700 | 700 | 700 | 700 | 700 | 700 | 700 | 700 | 700 | 700 | 700 | 700 | |
| Installation Clearances | NV F | Top | mm | 200 | | | | | | | | | | | | |
| | | LH Side | mm | 200 | | | | | | | | | | | | |
| | | RH Side | mm | 1000 | | | | | | | | | | | | |
| | | Rear | mm | 400 | | | | | | | | | | | | |
| Flue | Diameter | | mm Ø | 80 | 80 | 80 | 80 | 100 | 100 | 100 | 130 | 130 | 130 | 130 | 130 | |
| | Maximum Length | Flue Only | m | 12 | | | | | | | | | | | | |
| | | Room Sealed | m | 6 | | | | | | | | | | | | |
| Combustion Air Spigot | | | mm Ø | 80 | 80 | 80 | 80 | 100 | 100 | 100 | 130 | 130 | 130 | 130 | 130 | |
| Noise Level | | | dB(A) | 42 | 50 | 48 | 49 | 50 | 54 | 57 | 58 | 58 | 62 | 63 | 63 | |
| Nett Weight | NV F | | kg | 53 | 54 | 68 | 89 | 89 | 93 | 114 | 130 | 150 | 188 | 260 | 260 | |
| | NV C | | kg | 92 | 107 | 121 | 127 | 167 | 169 | 183 | 213 | 234 | 303 | 364 | 424 | |

Notes:

Fuel Consumption and output figures based upon nett calorific values as follows:

Natural Gas (G20) nett CV 34.02 MJ/m³

Propane (G31) nett CV 95.65 MJ/m³

Heaters have efficiency levels which meet with the minimum efficiency requirements of UK PartL2B Building Regulations

Heaters have efficiency levels which meet the criteria of the Enhanced Capital Allowance Scheme

Air handling data is assessed at room ambient conditions

Throw figures provide the distance to the point where the terminal velocity degrades to 0.25m/s

Dimensions and clearance data in the table above refer to NV F units only - for NV C and NV D data refer to the dimensions page and/or the installation instructions

Noise levels are applicable to standard NV F models and are measured 5m from appliance in free field conditions

Motor kW, run and start amps apply to standard electrical supply as stated. For optional data contact sales office

Connection of combustion air duct is not required for 'flue only' applications

It is the responsibility of the installing contractor to ensure that ductwork is correctly sized and balanced when installing NVx Centrifugal units

Installer guidance notes on rear page

Dimensions

NVx F - Axial Fan Crossflow Units

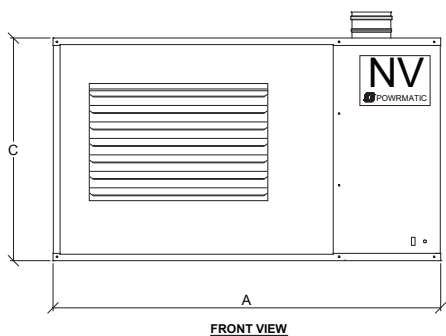

FRONT VIEW

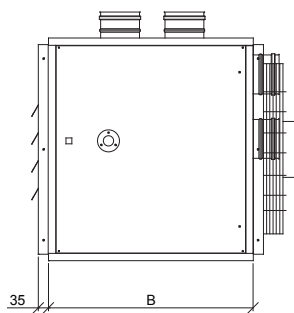

R/H SIDE VIEW

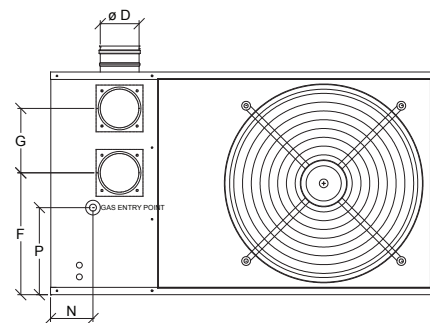

REAR VIEW

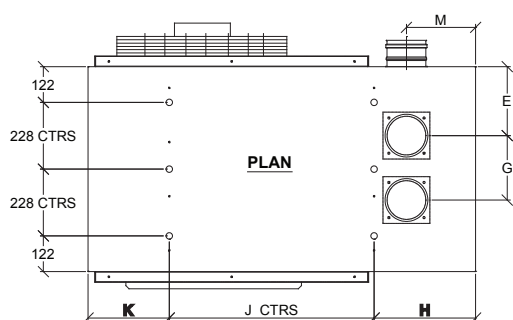

PLAN

Note: For dimensioning purposes, both top and rear flue and combustion air connections are shown.

| MODEL | 10 | 15 | 20 | 25 | 30 | 40 | 50 | 60 | 75 | 90 | 120 | 140 |
|-------|-----|-----|-------|-------|-------|-------|-------|-------|-------|-------|-------|-------|
| A | 785 | 785 | 1000 | 1000 | 1000 | 1000 | 1000 | 1325 | 1325 | 2325 | 2325 | 2325 |
| B | 700 | 700 | 700 | 700 | 700 | 700 | 700 | 700 | 700 | 700 | 700 | 700 |
| C | 540 | 540 | 540 | 540 | 760 | 760 | 912 | 760 | 912 | 700 | 831 | 975 |
| DØ | 80 | 80 | 80 | 80 | 100 | 100 | 100 | 130 | 130 | 130 | 130 | 130 |
| E | 248 | 248 | 248 | 248 | 233.5 | 233.5 | 233.5 | 235.5 | 235.5 | 235.5 | 235.5 | 235.5 |
| F | 308 | 308 | 308 | 308 | 492 | 492 | 644 | 416 | 568 | 321 | 487 | 631 |
| G | 120 | 120 | 120 | 120 | 142 | 142 | 142 | 220 | 220 | 220 | 220 | 220 |
| H | 317 | 317 | 317 | 317 | 317 | 317 | 317 | 347 | 347 | 347 | 347 | 347 |
| J | 250 | 250 | 450 | 450 | 450 | 450 | 450 | 700 | 700 | 2x850 | 2x850 | 2x850 |
| K | 218 | 218 | 232.5 | 232.5 | 232.5 | 232.5 | 232.5 | 278 | 278 | 278 | 278 | 278 |
| M | 216 | 216 | 216 | 216 | 206 | 206 | 206 | 236 | 236 | 246 | 246 | 246 |
| N | 114 | 114 | 114 | 114 | 114 | 114 | 114 | 145 | 145 | 88 | 88 | 88 |
| P | 194 | 194 | 194 | 225.5 | 297 | 297 | 374 | 297 | 374 | 243 | 326 | 398 |

NVx C - Centrifugal Fan Units

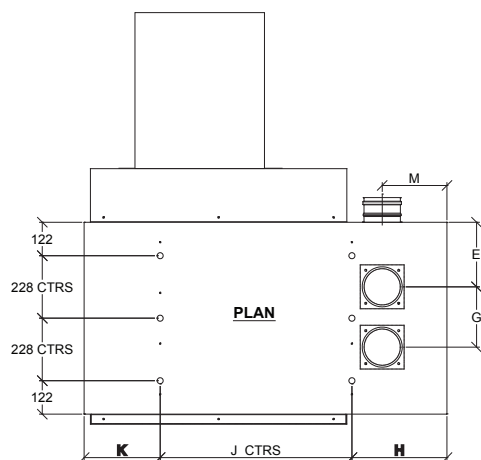
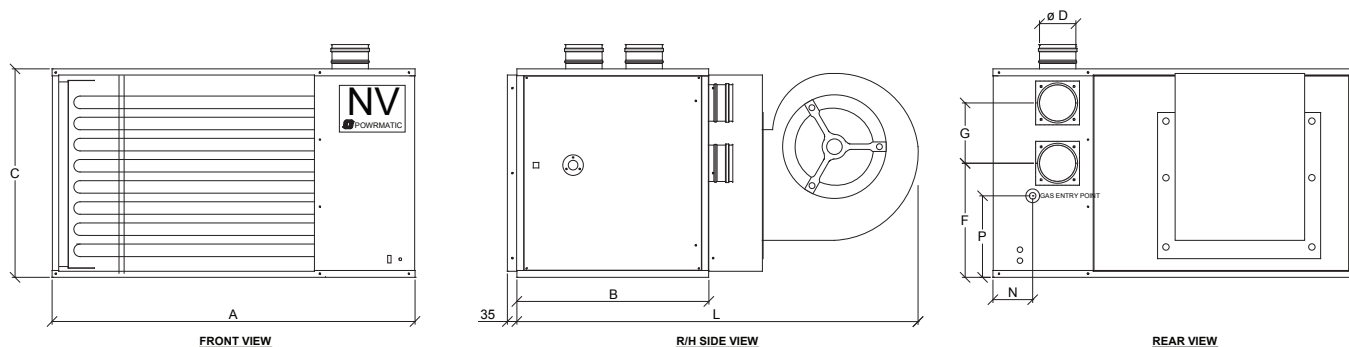

Note: For dimensioning purposes, both top and rear flue and combustion air connections are shown.

| MODEL | 10 | 15 | 20 | 25 | 30 | 40 | 50 | 60 | 75 | 90 | 120 | 140 |
|-----------|------|------|-------|-------|-------|-------|-------|-------|-------|-------|-------|-------|
| A | 785 | 785 | 1000 | 1000 | 1000 | 1000 | 1000 | 1325 | 1325 | 2325 | 2325 | 2325 |
| B | 700 | 700 | 700 | 700 | 700 | 700 | 700 | 700 | 700 | 700 | 700 | 700 |
| C | 540 | 540 | 540 | 540 | 760 | 760 | 912 | 760 | 912 | 700 | 831 | 975 |
| DØ | 80 | 80 | 80 | 80 | 100 | 100 | 100 | 130 | 130 | 130 | 130 | 130 |
| E | 248 | 248 | 248 | 248 | 233.5 | 233.5 | 233.5 | 235.5 | 235.5 | 235.5 | 235.5 | 235.5 |
| F | 308 | 308 | 308 | 308 | 492 | 492 | 644 | 416 | 568 | 321 | 487 | 631 |
| G | 120 | 120 | 120 | 120 | 142 | 142 | 142 | 220 | 220 | 220 | 220 | 220 |
| H | 317 | 317 | 317 | 317 | 317 | 317 | 317 | 347 | 347 | 347 | 347 | 347 |
| J | 250 | 250 | 450 | 450 | 450 | 450 | 450 | 700 | 700 | 2x850 | 2x850 | 2x850 |
| K | 218 | 218 | 232.5 | 232.5 | 232.5 | 232.5 | 232.5 | 278 | 278 | 278 | 278 | 278 |
| L | 1317 | 1317 | 1356 | 1356 | 1430 | 1430 | 1430 | 1505 | 1505 | 1430 | 1505 | 1505 |
| M | 216 | 216 | 216 | 216 | 206 | 206 | 206 | 236 | 236 | 246 | 246 | 246 |
| N | 114 | 114 | 114 | 114 | 114 | 114 | 114 | 145 | 145 | 88 | 88 | 88 |
| P | 194 | 194 | 194 | 225.5 | 297 | 297 | 374 | 297 | 374 | 243 | 326 | 398 |
| S | 422 | 637 | 637 | 637 | 637 | 637 | 637 | 932 | 932 | 1932 | 1932 | 1932 |
| T | 492 | 492 | 492 | 492 | 712 | 712 | 864 | 712 | 864 | 617 | 783 | 927 |

Dimensions

NVC/FS units - Centrifugal Heater with fan plenum fitted

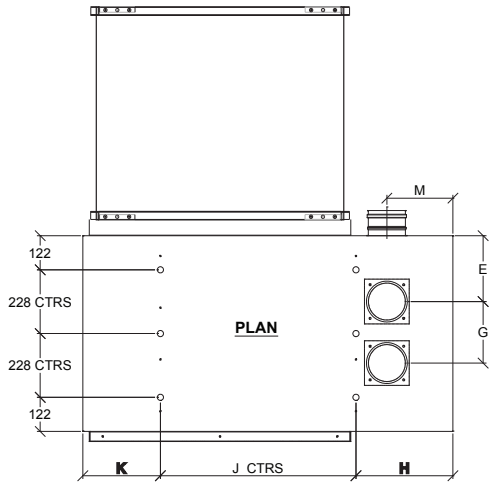
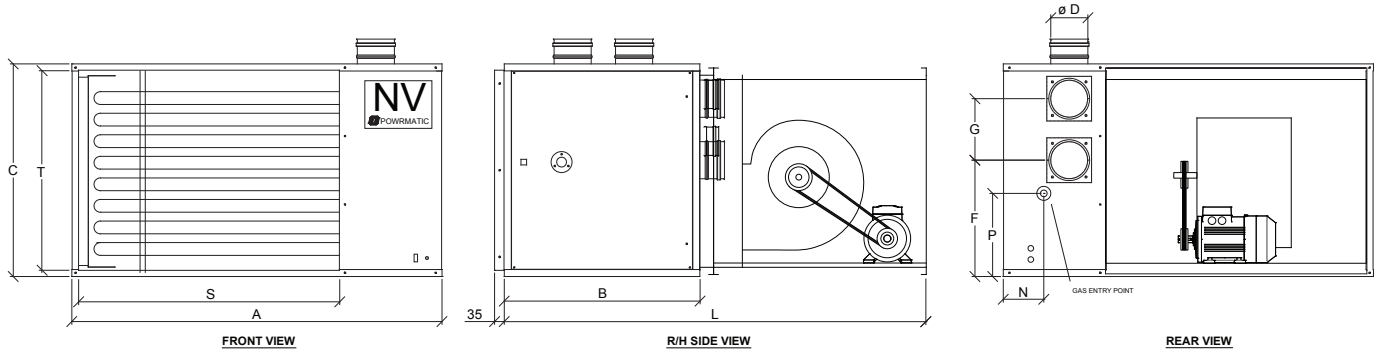

Note: For dimensioning purposes, both top and rear flue and combustion air connections are shown.

| MODEL | 10 | 15 | 20 | 25 | 30 | 40 | 50 | 60 | 75 | 90 | 120 | 140 |
|-----------|-----|-----|-------|-------|-------|-------|-------|-------|-------|-------|-------|-------|
| A | 785 | 785 | 1000 | 1000 | 1000 | 1000 | 1000 | 1325 | 1325 | 2325 | 2325 | 2325 |
| B | 700 | 700 | 700 | 700 | 700 | 700 | 700 | 700 | 700 | 700 | 700 | 700 |
| C | 540 | 540 | 540 | 540 | 760 | 760 | 912 | 760 | 912 | 700 | 831 | 975 |
| DØ | 80 | 80 | 80 | 80 | 100 | 100 | 100 | 130 | 130 | 130 | 130 | 130 |
| E | 248 | 248 | 248 | 248 | 233.5 | 233.5 | 233.5 | 235.5 | 235.5 | 235.5 | 235.5 | 235.5 |
| F | 308 | 308 | 308 | 308 | 492 | 492 | 644 | 416 | 568 | 321 | 487 | 631 |
| G | 120 | 120 | 120 | 120 | 142 | 142 | 142 | 220 | 220 | 220 | 220 | 220 |
| H | 317 | 317 | 317 | 317 | 317 | 317 | 317 | 347 | 347 | 347 | 347 | 347 |
| J | 250 | 250 | 450 | 450 | 450 | 450 | 450 | 700 | 700 | 2x850 | 2x850 | 2x850 |
| K | 218 | 218 | 232.5 | 232.5 | 232.5 | 232.5 | 232.5 | 278 | 278 | 278 | 278 | 278 |
| M | 216 | 216 | 216 | 216 | 206 | 206 | 206 | 236 | 236 | 246 | 246 | 246 |
| N | 114 | 114 | 114 | 114 | 114 | 114 | 114 | 145 | 145 | 88 | 88 | 88 |
| P | 194 | 194 | 194 | 225.5 | 297 | 297 | 374 | 297 | 374 | 243 | 326 | 398 |
| Q | 133 | 133 | 133 | 133 | 147 | 147 | 147 | 147 | 147 | 147 | 147 | 147 |
| S | 422 | 637 | 637 | 637 | 637 | 637 | 637 | 932 | 932 | 1932 | 1932 | 1932 |
| T | 492 | 492 | 492 | 492 | 712 | 712 | 864 | 712 | 864 | 617 | 783 | 927 |

Flue Arrangements

single wall - horizontal flue system

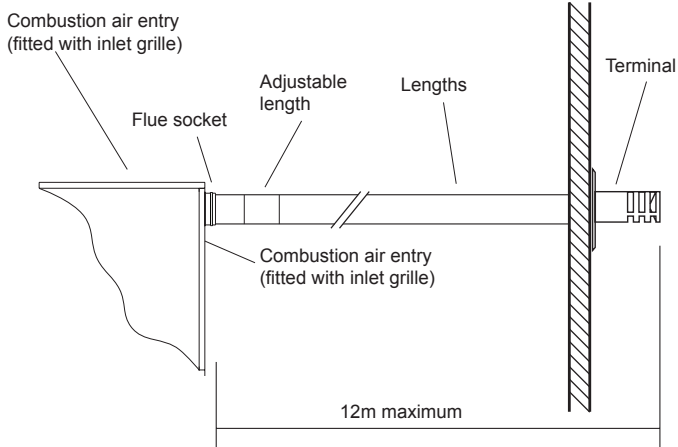

room sealed - horizontal flue system

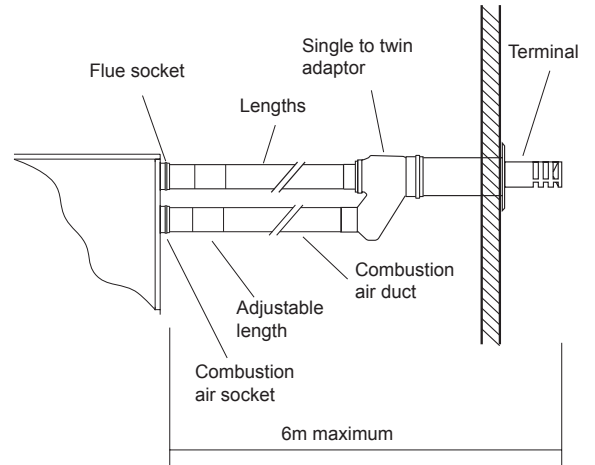

single wall - vertical flue system

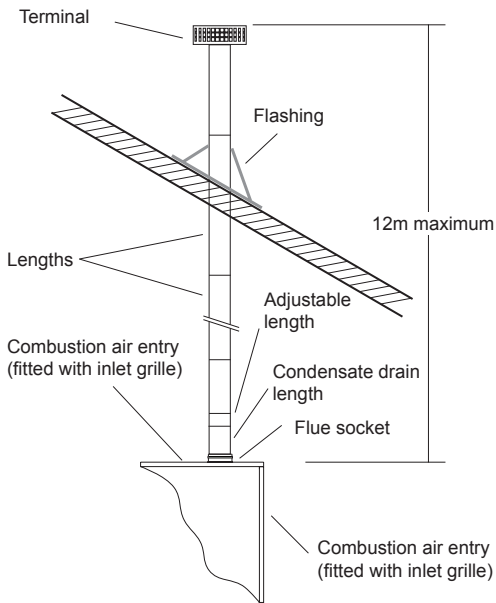

room sealed - vertical flue system

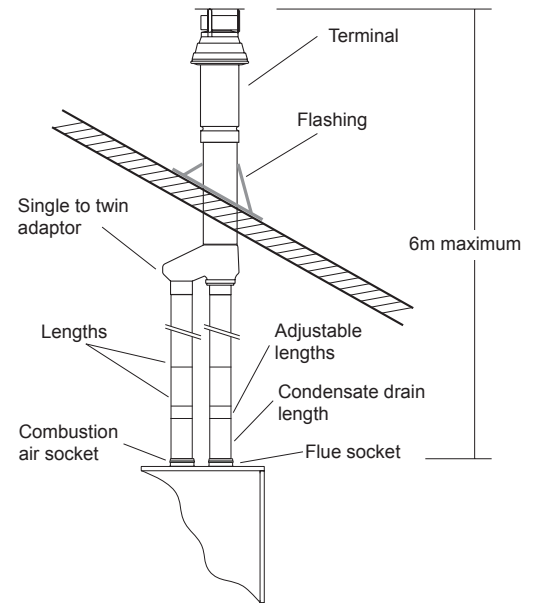

Notes for all systems:

1. Final overall length of adjustable disconnection piece must be between 360-415mm.
2. 45° offsets may be used if required. Each set is equivalent to 0.5m of flue length.
3. Where nxv heaters are used in clean environments it is permissible to take the combustion air directly from the heated space. The supplied mesh intake plate must be fitted to the combustion air inlet on the rear of the heater.

Installer Guide

General The following notes are provided as a help, however installers and operators should fully acquaint themselves with the more detailed guidance provided in the relevant installation manual. For copies of such manuals please consult our technical department or visit our website - www.powrmatic.co.uk

Standards All Powrmatic nvx heaters must be installed, commissioned and operated with due regard to appropriate regulations including but not limited to BS 6230 2005, relevant Codes of Practice, the possible requirements of Local Authorities, Fire Officers and insurers as well as Powrmatic's installation manual.

Position & Location Powrmatic nvx heaters can be 'drop rod' suspended via purpose designed M10 suspension fixing points, attached to our optional wall support brackets or positioned on a level non-combustible base. In all cases it is important that all supporting structures have due regard to the relevant weight loadings.

Consideration should also be given to flue routes and points of exit, gas, electrical and control connections, the throw characteristics of the heater, issues of public access and the siting of environmental control stations and/or remote temperature sensors where the position needs to be representative of the zone temperature to which they refer.

Heaters should not be installed in hazardous areas or areas where there is a foreseeable risk of flammable or corrosion inducing particles, gases or vapours being drawn into the combustion air or main fan circuits.

Areas where special consideration or advice may be required could include but is not limited to -

- where de-greasing solvents are present, even in minute concentrations
- where paint spraying is carried out
- where styrenes or other laminating products are used
- where airborne silicone is present
- where petrol engined vehicles are stored or maintained
- where dust is present (ie wood working or joinery shops)
- where high levels of extract persist

Installation in such areas may be possible under specific conditions. Please consult our technical department for further information.

Plant Room or Enclosure Locations It is recommended that you consult with our technical department.

Hort Bridge
Ilminster
Somerset
TA19 9PS
United Kingdom

Tel: +44(0) 1460 53535
Fax: +44(0) 1460 52341
web: www.powrmatic.co.uk
e-mail: info@powrmatic.co.uk

Combustion Air & General Ventilation Within the United Kingdom mandatory regulations apply concerning the provision of combustion air and general heater ventilation. Where a heater is installed in room sealed mode (ie where both the flue exit and combustion air and positively connected to atmosphere) then there is no specific requirement for combustion air ventilation. However, depending upon location, provision for general ventilation may still be a necessity.

If the heater is installed in flue only mode and directly within the heated space and where that heated space has a natural ventilation rate greater than 0.5 air changes per hour then combustion air and general heater ventilation is probably not required. If the heated space has a natural ventilation rate of less than 0.5 air changes per hour then either natural ventilator openings or mechanical ventilation will be required. Please consult the installation manual for further details.

Installation Clearances Particular clearances may be necessary for the correct and safe function of the heater as well as for maintenance purposes. Such clearances are confirmed in the relevant installation manual.

Flue Powrmatic nvx heaters can be installed in either room sealed or flue only mode. Each heater requires a separate flue and/or combustion air intake system of the appropriate size and type. Installers are reminded that type approval has been granted for these appliances on the basis that they are fitted with Powrmatic nvx flue systems. Maximum lengths apply and should be strictly observed.

Systems may be installed in either the horizontal or vertical plane. In either case the number of bends kept to a minimum and regard must be given to the reduction in permissible length with the addition of each bend. The flue must be adequately supported and terminated with the approved terminal assembly, with due regard to the point of exit and its proximity to any windows, doors or ventilation intakes etc.

Pipework Care should be taken when sizing pipework to ensure that minimum gas inlet pressures are not compromised under dynamic load conditions. Isolating valves and service unions should be provided for each heater and pipework installed with due regard for relevant standards and Codes of Practice.

Guarantee Powrmatic nvx heaters are provided with a comprehensive guarantee covering both the heater and the heat exchanger. For United Kingdom sales the heater has the benefit of a **two** year parts and **one** year labour guarantee whilst the heat exchanger assembly has a **ten** year time related warranty. All guarantees are subject to terms and conditions.

45 Broomhill Close
Tallaght
Dublin 24
Rep. of Ireland

Tel: +353(1) 1452 1533
Fax: +353(1) 1452 1764
web: www.powrmatic.ie
e-mail: info@powrmatic.ie

Powrmatic pursues a policy of continuous improvement in both design and performance of its products and therefore reserves the right to change, amend or vary specifications without notice. Whilst the details contained herein are believed to be correct they do not form the basis of any contract and interested parties should contact the Company to confirm whether any material alterations have been made since publication of this brochure.

